

Series ACS - ACC- 85°C 5.000h

Capacitors PCB type

- ACC 2 pins
- ACS 4 pins
- Capacitance Tolerance: -20 + 20% - standard (M)
- Climatic category: 40/85/56
- Case: 30x40 - 45x100
- Temperature - 40°C + 85°C

Mechanical Outlines

- Case: aluminium made
- Terminals: solder pin
- Sealing: hermetic on Rubber Bakelite cover
- Pressure Release Vent: onto aluminium case
- No insulated bottom
- Sleeve: self-extinguishing thermo shrinkable
- Size: see enclosed drawings
- External Material UL94-V0

Ordering Code: Example

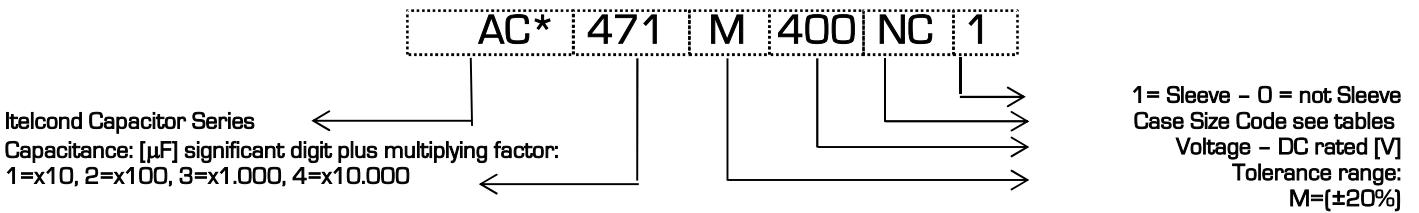

Ripple Current

The allowable values of ripple current in Ampères, are related to the temperature and frequency by following equation:

$$I_{Ripple} = K_t \cdot K_f \cdot I_{Ripple@85^\circ C}$$

Where:

- $I_{Ripple@85^\circ C}$ is the limit given by tables, @ 85°C/100HZ
- K_t is the Temperature Correlation Factor
- K_f is the Frequency Correlation Factor

Note .Superimposed alternating voltage summed to DC volage must not exceed rated voltage, rated ripple current must not be exceeded and no reverse polarity is allowed

°C	40	55	65	75	85
K_t	2.30	1.90	1.70	1.40	1.00

Table 1- K_t Values

	K_f	
V_n/Hz	$V < 50$	$V > 50$
50	0.90	0.88
100	1.00	1.00
300	1.14	1.20
400	1.18	1.25
500	1.20	1.35
>1000	1.25	1.40

Table 2- K_f Values

Expected Lifetime End of Life Criteria

During useful life typical electrical parameters of electrolytic capacitor are subject to change.

End of Life criteria, when rated temperature, voltage and ripple are applied, are:

$$\frac{\Delta C}{C_{t0}} \leq 30\% \quad \text{Equation 1}$$

$$ESR \leq 3 \cdot ESR_{t0} \quad \text{Equation 2}$$

$$I_f \leq I_{ft0} \quad \text{Equation 3}$$

where t_0 is the initial value

Voltage Endurance Test Requirements

On Voltage Endurance Test are based Expected Lifetime Curves.

End of Life criteria, when rated temperature, and voltage are applied for 2'000hrs, are

$$\frac{\Delta C}{C_{t0}} \leq 10\% \quad \text{Equation 4}$$

$$ESR \leq 1,3 \cdot ESR_{t0} \quad \text{Equation 5}$$

$$I_f \leq I_{ft0} \quad \text{Equation 6}$$

where t_0 is the initial value

Expected Lifetime Vs Temperature and Ripple Current

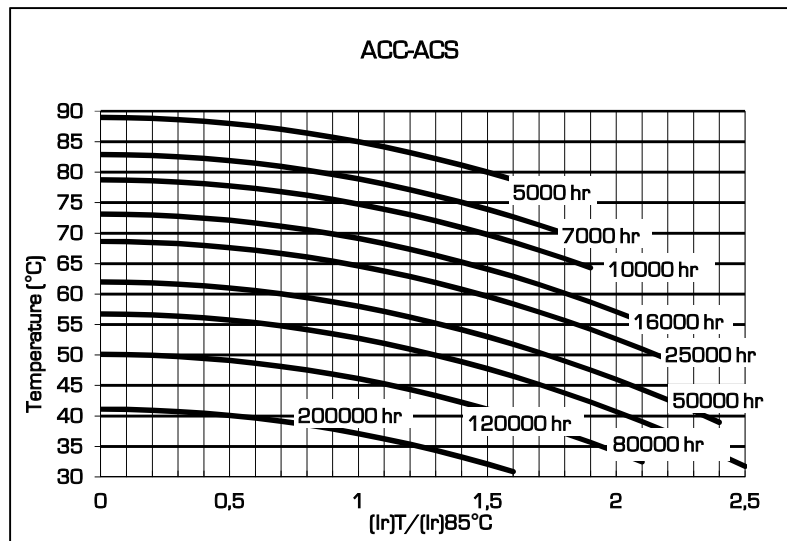

Table 3

Leakage Current

After the rated voltage has been applied to the capacitor for 5 minutes the leakage current must be within those limits.

Maximum limit	@25°C	$I_f \leq 0,004 \times C \times V$
Operating limit	@25°C	$I_f \leq 0,001 \times C \times V$

Where: I_f =leakage current [μ A], C =capacitance [μ F], V =rated voltage [V]

Surge Voltage

Working Voltage	40	50	63	75	100	160	200	250	350	400	450	500
Surge Voltage	46	58	73	86	115	185	230	290	385	440	495	525

	Capacitance	Case	Diam	Height	Tanδ	ESRmax typ		Zmax	Iripple @100Hz		Ordering Code
	[μF]@100Hz		[mm]	[mm]	[%]@100Hz	[mΩ]@100Hz	[mΩ]@10KHz	[mΩ]@10KHz	[A]@55°C	[A]@85°C	* = C, 2 Pins S, 4 Pins
40	6800	MB	30	40	0,30	56	45	42	8,2	4,3	AC*682M040MB1
	10000	MC	30	50	0,32	41	33	31	10,6	5,6	AC*103M040MC1
		NB	35	40	0,36	46	37	34	9,9	5,2	AC*103M040NB1
	15000	NC	35	50	0,36	31	24	23	13,3	7,0	AC*153M040NC1
	22000	PC	40	50	0,48	28	22	21	15,1	7,9	AC*223M040PC1
	33000	PE	40	75	0,48	19	15	14	22,0	11,6	AC*333M040PE1
	47000	PG	40	100	0,48	13	10	10	29,9	15,7	AC*473M040PG1
63	4700	MB	30	40	0,21	57	46	43	8,1	4,3	AC*472M063MB1
	6800	MC	30	50	0,21	39	31	30	10,8	5,7	AC*682M063MC1
		NB	35	40	0,24	45	36	34	10,0	5,3	AC*682M063NB1
	10000	NC	35	50	0,24	31	24	23	13,3	7,0	AC*103M063NC1
	12000	PC	40	50	0,29	31	25	23	14,4	7,6	AC*123M063PC1
	15000	PE	40	75	0,29	25	20	18	19,1	10,1	AC*153M063PE1
	22000	PG	40	100	0,29	17	13	13	26,3	13,8	AC*223M063PG1
100	1500	MB	30	40	0,09	76	61	57	7,0	3,7	AC*152M100MB1
	2200	MC	30	50	0,10	58	46	43	8,9	4,7	AC*222M100MC1
		NB	35	40	0,11	64	51	48	8,4	4,4	AC*222M100NB1
	3300	MC	30	50	0,12	46	37	35	9,9	5,2	AC*332M100MC1
	4700	NC	35	50	0,12	33	26	24	12,9	6,8	AC*472M100NC1
	5600	PC	40	50	0,12	27	22	20	15,2	8,0	AC*562M100PC1
	6800	PE	40	75	0,12	22	18	17	20,0	10,5	AC*682M100PE1
10000	PG	40	100	0,12	15	12	11	27,6	14,5	AC*103M100PG1	
200	680	MB	30	40	0,08	150	120	112	5,0	2,6	AC*681M200MB1
	1000	NB	35	40	0,08	102	82	76	6,7	3,5	AC*102M200NB1
	1200	MC	30	50	0,08	85	68	64	7,3	3,9	AC*122M200MC1
	1500	NC	35	50	0,08	68	54	51	8,9	4,7	AC*152M200NC1
	2200	NC	35	50	0,08	46	37	35	10,8	5,7	AC*222M200NC1
	2700	PE	40	75	0,08	38	30	28	15,4	8,1	AC*272M200PE1
	3300	PG	40	100	0,08	31	25	23	19,4	10,2	AC*332M200PG1
		QC	45	50	0,08	31	25	23	15,4	8,1	AC*332M200QC1
	3900	QE	45	75	0,08	26	21	20	19,8	10,4	AC*392M200QE1
4700	GG	45	100	0,08	22	17	16	24,7	13,0	AC*472M200GG1	
250	470	MB	30	40	0,08	217	173	163	4,2	2,2	AC*471M250MB1
	1000	MC	30	50	0,08	102	82	76	6,7	3,5	AC*102M250MC1
		NB	35	40	0,08	102	82	76	6,7	3,5	AC*102M250NB1
	1500	NC	35	50	0,08	68	54	51	8,9	4,7	AC*152M250NC1
	1800	PC	40	50	0,08	57	45	42	10,6	5,6	AC*182M250PC1
	2200	NE	35	75	0,08	46	37	35	12,9	6,8	AC*222M250NE1
		QC	45	50	0,08	46	37	35	12,5	6,6	AC*222M250QC1
	2700	PE	40	75	0,08	38	30	28	15,4	8,1	AC*272M250PE1
3300	PG	40	100	0,08	31	25	23	19,4	10,2	AC*332M250PG1	

	Capacitance	Case	Diam	Height	Tanδ	ESRmax typ		Zmax	Iripple @100Hz		Ordering Code	
	[μF]@100Hz		[mm]	[mm]	[%]@100Hz	[mΩ]@100Hz		[mΩ]@10KHz	[A]@55°C	[A]@85°C	* = C, 2 Pins S, 4 Pins	
250	3300	QE	45	75	0,08	31	25	23	18,2	9,6	AC*332M250QE1	
	3900	GG	45	100	0,08	26	21	20	22,5	11,8	AC*392M250GG1	
400	220	MB	30	40	0,10	579	463	434	3,3	1,7	AC*221M400MB1	
	330	MB	30	40	0,10	386	309	290	4,0	2,1	AC*331M400MB1	
		MC	30	50	0,10	386	309	290	4,4	2,3	AC*331M400MC1	
	390	MB	30	40	0,10	327	261	245	4,3	2,3	AC*391M400MB1	
		MC	30	50	0,10	327	261	245	4,8	2,5	AC*391M400MC1	
		NC	35	50	0,10	327	261	245	5,2	2,7	AC*391M400NC1	
	470	MC	30	50	0,10	271	217	203	5,2	2,8	AC*471M400MC1	
		NB	35	40	0,10	271	217	203	5,2	2,7	AC*471M400NB1	
		NC	35	50	0,10	271	217	203	5,7	3,0	AC*471M400NC1	
		PB	40	40	0,10	271	217	203	5,6	3,0	AC*471M400PB1	
	560	NN	35	60	0,10	271	217	203	6,2	3,2	AC*471M400NN1	
		NC	35	50	0,10	227	182	171	6,2	3,3	AC*561M400NC1	
		680	NC	35	50	0,10	187	150	141	6,9	3,6	AC*681M400NC1
			NN	35	60	0,10	187	150	141	7,4	3,9	AC*681M400NN1
	NE		35	75	0,10	187	150	141	8,2	4,3	AC*681M400NE1	
	PC		40	50	0,10	187	150	141	7,4	3,9	AC*681M400PC1	
	820	NN	35	60	0,10	155	124	117	8,2	4,3	AC*821M400NN1	
		NE	35	75	0,10	155	124	117	9,0	4,7	AC*821M400NE1	
		PC	40	50	0,10	155	124	117	8,1	4,3	AC*821M400PC1	
	1000	NN	35	60	0,10	127	102	96	9,0	4,7	AC*102M400NN1	
		NE	35	75	0,10	127	102	96	9,9	5,2	AC*102M400NE1	
		PN	40	60	0,10	127	102	96	9,7	5,1	AC*102M400PN1	
		PE	40	75	0,10	127	102	96	10,7	5,6	AC*102M400PE1	
		QC	45	50	0,10	127	102	96	9,6	5,1	AC*102M400QC1	
1200	NE	35	75	0,10	106	85	80	10,9	5,7	AC*122M400NE1		
	PE	40	75	0,10	106	85	80	11,7	6,2	AC*122M400PE1		
1500	PE	40	75	0,10	85	68	64	13,1	6,9	AC*152M400PE1		
	PG	40	100	0,10	85	68	64	14,9	7,8	AC*152M400PG1		
	QN	45	60	0,10	85	68	64	12,7	6,7	AC*152M400QN1		
	QE	45	75	0,10	85	68	64	14,0	7,4	AC*152M400QE1		
	QG	45	100	0,10	85	68	64	15,9	8,4	AC*152M400QG1		
1800	QE	45	75	0,10	71	57	53	15,3	8,1	AC*182M400QE1		
2200	QG	45	100	0,10	58	46	43	19,3	10,1	AC*222M400QG1		
450	150	MB	30	40	0,12	1019	815	764	2,5	1,3	AC*151M450MB1	
	220	MB	30	40	0,12	695	556	521	3,0	1,6	AC*221M450MB1	
	330	MC	30	50	0,12	463	371	347	4,0	2,1	AC*331M450MC1	
		NB	35	40	0,12	463	371	347	4,0	2,1	AC*331M450NB1	
		NC	35	50	0,12	463	371	347	4,4	2,3	AC*331M450NC1	
	470	NC	35	50	0,12	325	260	244	5,2	2,7	AC*471M450NC1	
NN		35	60	0,12	325	260	244	5,6	3,0	AC*471M450NN1		

	Capacitance	Case	Diam	Height	Tanδ	ESRmax typ		Zmax	Iripple @100Hz		Ordering Code
	[μF]@100Hz		[mm]	[mm]	[%]@100Hz	[mΩ]@100Hz	[mΩ]@10KHz	[mΩ]@10KHz	[A]@55°C	[A]@85°C	*= C, 2 Pins S, 4 Pins
450	470	PB	40	40	0,12	325	260	244	5,1	2,7	AC*471M450PB1
	560	NC	35	50	0,12	273	218	205	5,7	3,0	AC*561M450NC1
		NE	35	75	0,12	273	218	205	6,8	3,6	AC*561M450NE1
		PC	40	50	0,12	273	218	205	6,1	3,2	AC*561M450PC1
		PE	40	75	0,12	273	218	205	7,3	3,8	AC*561M450PE1
	680	NN	35	60	0,12	225	180	169	6,8	3,6	AC*681M450NN1
		NE	35	75	0,12	225	180	169	7,5	3,9	AC*681M450NE1
		PC	40	50	0,12	225	180	169	6,8	3,6	AC*681M450PC1
	820	NN	35	60	0,12	186	149	140	7,4	3,9	AC*821M450NN1
		NE	35	75	0,12	186	149	140	8,2	4,3	AC*821M450NE1
	1000	PN	40	60	0,12	153	122	115	8,9	4,7	AC*102M450PN1
		PE	40	75	0,12	153	122	115	9,8	5,1	AC*102M450PE1
		PG	40	100	0,12	153	122	115	11,1	5,9	AC*102M450PG1
		QC	45	50	0,12	153	122	115	8,8	4,6	AC*102M450QC1
	1360	PG	40	100	0,12	112	90	84	13,0	6,8	AC*1361X450PG1
1500	PG	40	100	0,12	102	82	76	13,6	7,2	AC*152M450PG1	
	QE	45	75	0,12	102	82	76	12,8	6,7	AC*152M450QE1	
1800	QG	45	100	0,12	85	68	64	15,9	8,4	AC*182M450QG1	
2200	QG	45	100	0,12	69	56	52	17,6	9,3	AC*222M450QG1	
2700	QG	45	100	0,12	71	58	49	18,4	10	AC*272M450QG1	
500	220	MC	30	50	0,15	869	695	651	2,1	1,1	AC*221M450MC1
	330	NC	35	50	0,15	579	463	434	2,9	1,5	AC*331M450NC1
	390	NC	35	50	0,15	490	392	367	3,1	1,6	AC*391M450NC1
	470	NN	35	60	0,15	407	325	305	3,7	1,9	AC*471M450NN1
	470	PC	40	50	0,15	407	325	305	3,7	1,9	AC*471M450PC1
	560	NE	35	75	0,15	341	273	256	4,5	2,3	AC*561M450NE1
	560	PC	40	50	0,15	341	273	256	4,0	2,1	AC*561M450PC1
	680	PN	40	60	0,15	281	225	211	4,8	2,5	AC*681M450PN1
	680	PE	40	75	0,15	281	225	211	5,3	2,8	AC*681M450PE1
	680	QC	45	50	0,15	281	225	211	4,8	2,5	AC*681M450QC1
	1000	PG	40	100	0,15	191	153	143	7,3	3,8	AC*102M450PG1
	1000	QE	45	75	0,15	191	153	143	6,9	3,6	AC*102M450QE1
	1200	QG	45	100	0,15	159	127	119	8,5	4,5	AC*122M450QG1

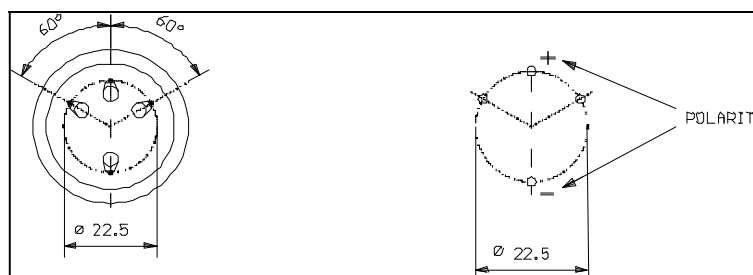
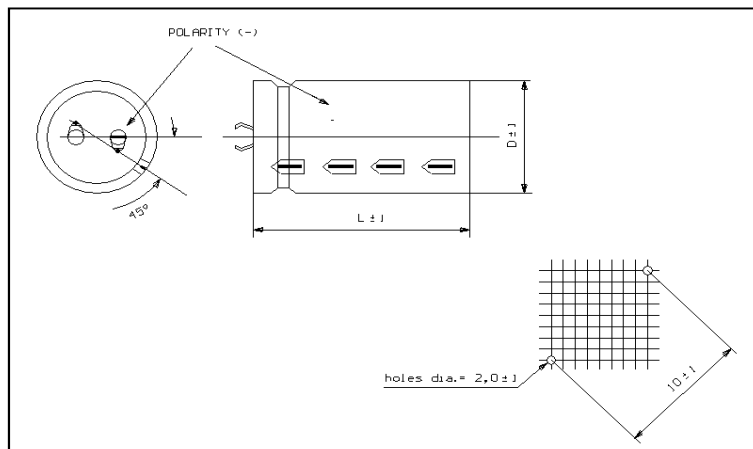
Dimension, Quantity and Weight for box

Case		Connections			Packaging	
Code	DxL	PIN			Pcs/Box	Weight/box
		ACC	ACS	Lenght		
MB	30x40	2		6.3	100	4-6
MC	30x50	2		6.3	100	4-6
NB	35x40	2	4	6.3	100	6-8
NC	35x50	2	4	6.3	100	6-8
NN	35x60	2	4	6.3	100	5-7
NE	35x75	2	4	6.3	50	6-8
PB	40x40	2	4	6.3	126	9-10
PC	40x50	2	4	6.3	126	9-10
PN	40x60	2	4	6.3	126	9-10
PE	40x75	2	4	6.3	63	7-9
PG	40x100	2	4	6.3	63	9-10
QC	45x50		4	6.3	30	6-8
QN	45x60		4	6.3	30	6-8
QE	45x75		4	6.3	30	7-9
QG	45x100		4	6.3	30	8-10

All dimensions in mm, torque in Nm, weight in kg